

Bill of material

800x600x530 mm

POS.	CAD-number	amount	article description	inside Dimension (mm)	material
1	D4899450147 <small>Rev.: A</small>	1	pallet / special /	800 x 600 x 144	Nadelholz IPPC /
2	D4899448372 <small>Rev.: A</small>	2	04 - Folder-type boxes and trays / 0452 /	794 x 993 x 5	DIN 2.30 EB /
3	D4899448369 <small>Rev.: A</small>	1	05 - Slide-type boxes / 0501 /	760 x 560 x 400	DIN 2.96/3 CAA /
4	TRICOR Corner <small>Rev.: 0</small>	8	plastic element / /	64.5 x 0 x 32	Other /
5	D4899449986 <small>Rev.: 0</small>	4	wood element / /	410 x 38 x 38	Nadelholz IPPC /
6	D048905608 <small>Rev.: 0</small>	4	corner protector / /	50 x 50 x 100	Vollpappe /



project description

H-pallet 3Wall 400mm

printing date

07.02.2024

Project weight (kg)

14.3

X000055494_A

Specification

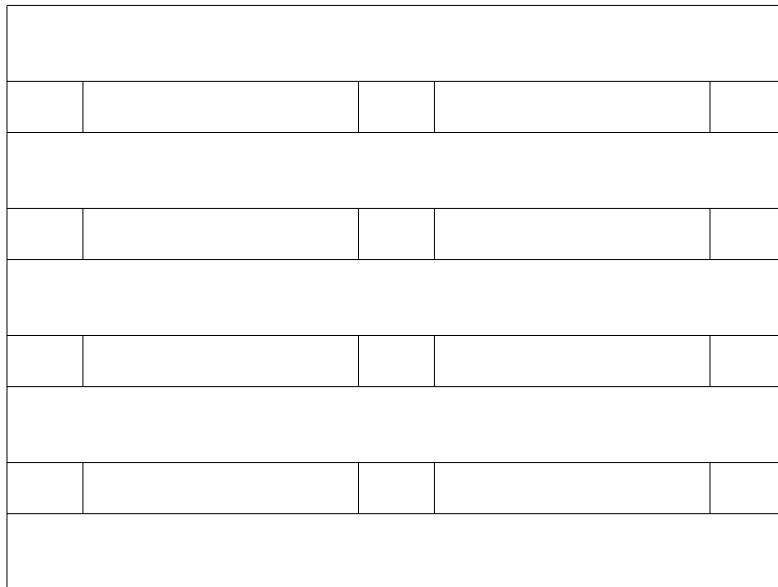
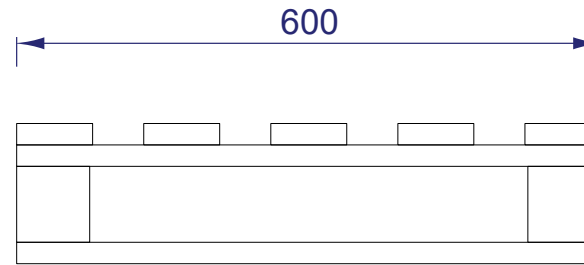
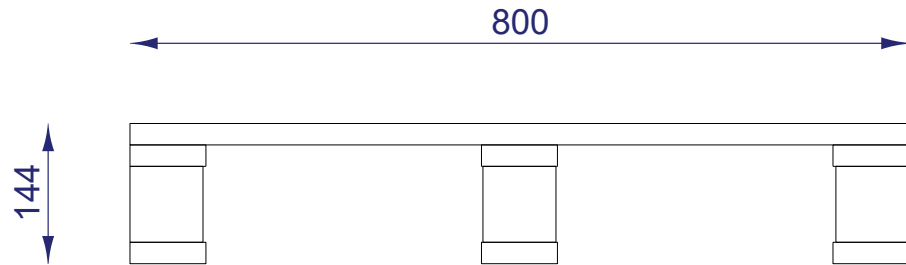

5 Top Board 800 x 78 x 22mm
3 Middle Board 600 x 78 x 22mm
6 Wooden Block 75 x 75 x 78mm
3 Bottom Board 600 x 78 x 22mm
Nailing: Min. 2 Grooved / screw nails per joint
Tolerance (+/-): 2mm
IPPC standard (yes/no): Yes, stamped
Residual moisture : Max. 20%

Drawing shows outside view



material: Nadelholz IPPC /	
dimension (mm): 800 x 600 x 144	
ascertained weight ca. (kg): 7.5	print:
calculated weight ca. (kg): 0.000	fastener:

Flute-/
Grain direction:



add. information:
Coniferous wood IPPC

Project description: H-pallet 3Wall 400mm	
Project-n°: X000055494_A	
CAD-n°: D4899450147	Rev. A
printing date : 07.02.2024	

Specification

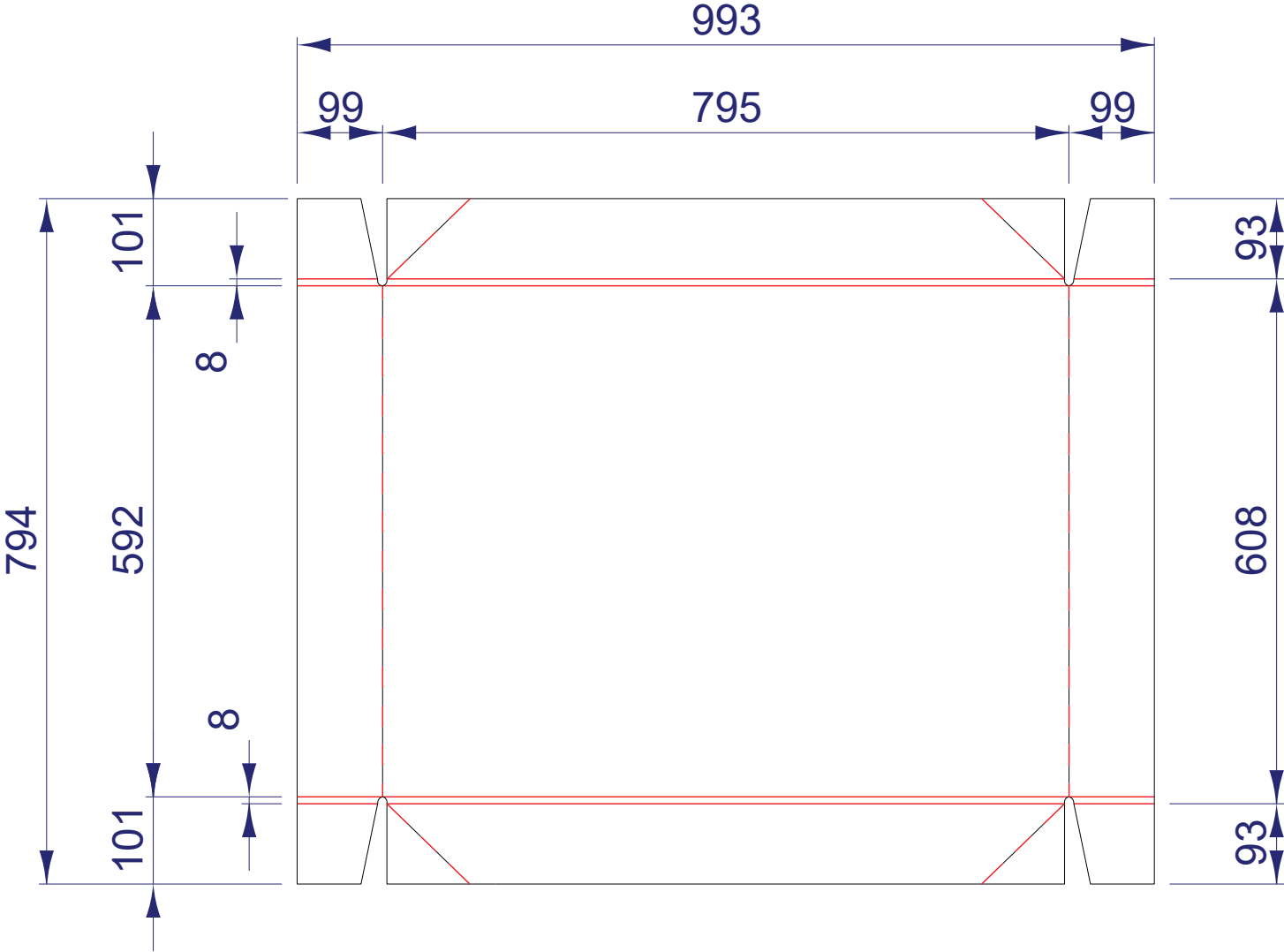

Drawing shows outside view



material: DIN 2.30 EB /	
dimension (mm): 794 x 993 x 5	
ascertained weight ca. (kg):	print:
calculated weight ca. (kg): 0.500	fastener: 4-corner stitched

Flute-/
Grain direction:



add. information:
H-pallet bottom and lid

Project description: H-pallet 3Wall 400mm	
Project-n°: X000055494_A	
CAD-n°: D4899448372	Rev. A
printing date: 07.02.2024	

Specification

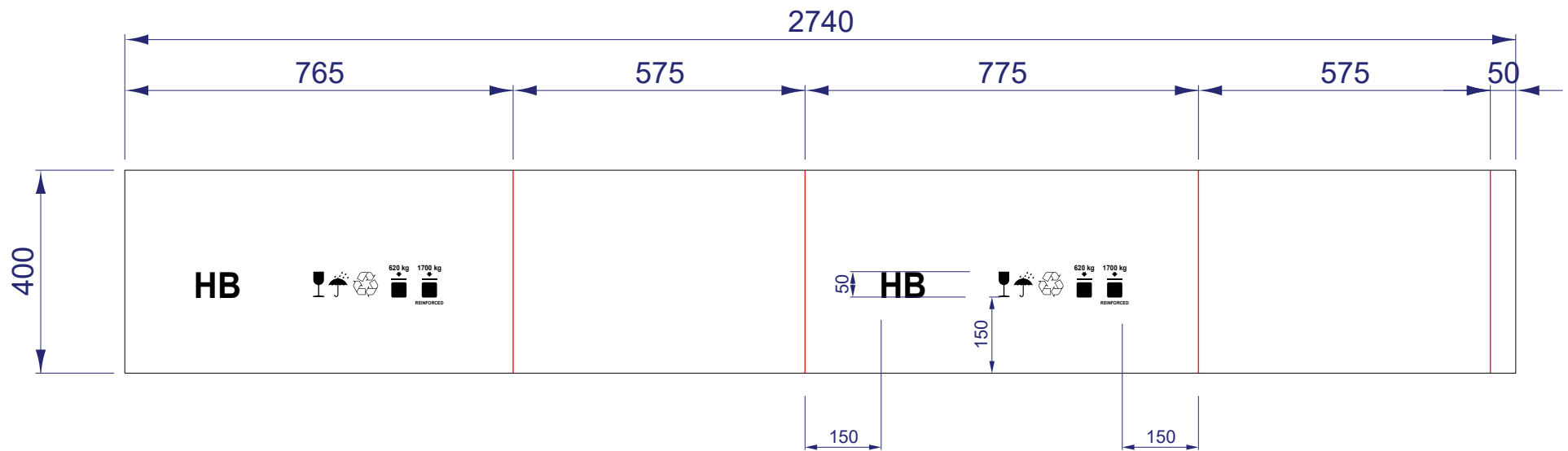

Drawing shows outside view



material: DIN 2.96/3 CAA /	
dimension (mm): 760 x 560 x 400	
ascertained weight ca. (kg):	print: 1-colored
calculated weight ca. (kg): 1.833	fastener: Inner flap glued and stitched

Flute-/
Grain direction:



add. information:
H-Ring 400mm

Project description: H-pallet 3Wall 400mm	
Project-n°: X000055494_A	
CAD-n°: D4899448369	Rev. A
printing date : 07.02.2024	

Specification

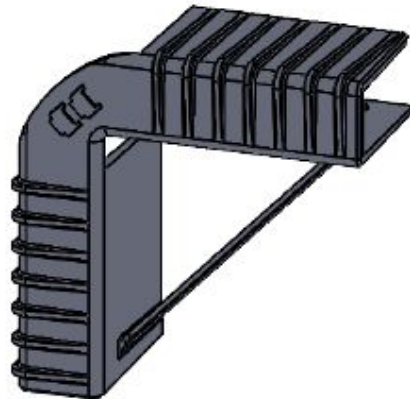
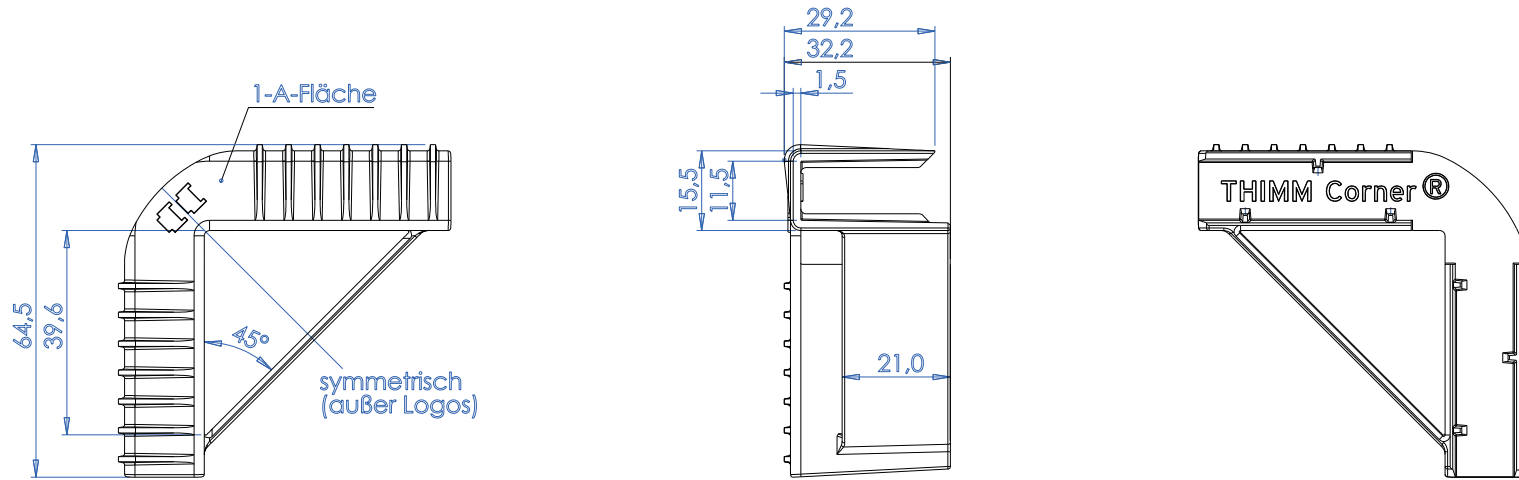

Toleranzen nach: DIN 16742 - TG3
 Material: Papercompound
 Gewicht: 13,35 g

Drawing shows outside view



material: Other /	
dimension (mm): 64.5 x 0 x 32	
ascertained weight ca. (kg):	print:
calculated weight ca. (kg): 0.000	fastener:

Flute-/
Grain direction:



Project description: H-pallet 3Wall 400mm	
Project-n°: X000055494_A	
CAD-n°:	Rev.
TRICOR Corner 0	
printing date: 07.02.2024	
add. information:	

Specification

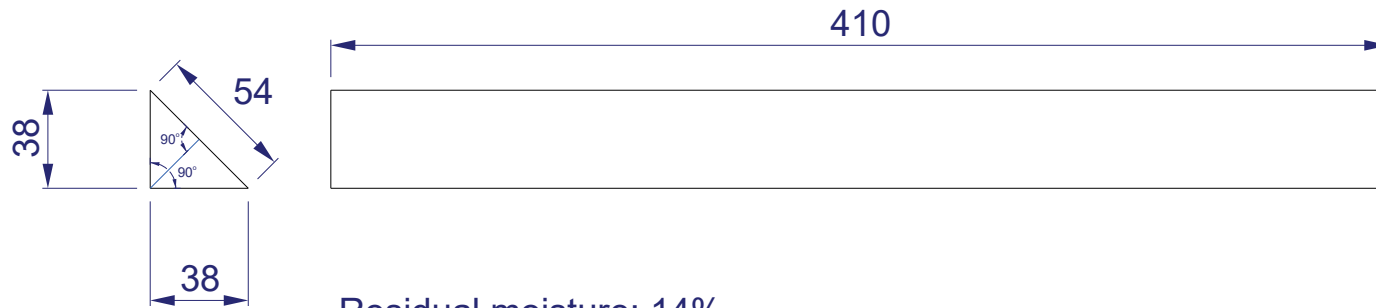

Residual moisture: 14%
 Tolerance
 38mm (+0/-1,5)
 54mm (+0/-2)
 410mm (+0/-2)

Apply IPPC stamp in the middle of the 54mm wide area

Wooden strips must be free of cracks and knots
 knotholes and clusters of knotholes.

not permitted
a ≠ b

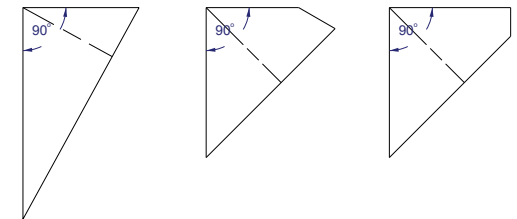

Drawing shows outside view



material: Nadelholz IPPC /	
dimension (mm): 410 x 38 x 38	
ascertained weight ca. (kg): 0.14	print:
calculated weight ca. (kg): 0.000	fastener:

Flute-/
 Grain direction:



add. information:
 Coniferous wood IPPC

Project description: H-pallet 3Wall 400mm	
Project-n°: X000055494_A	
CAD-n°: D4899449986	Rev. 0
printing date : 07.02.2024	

Specification

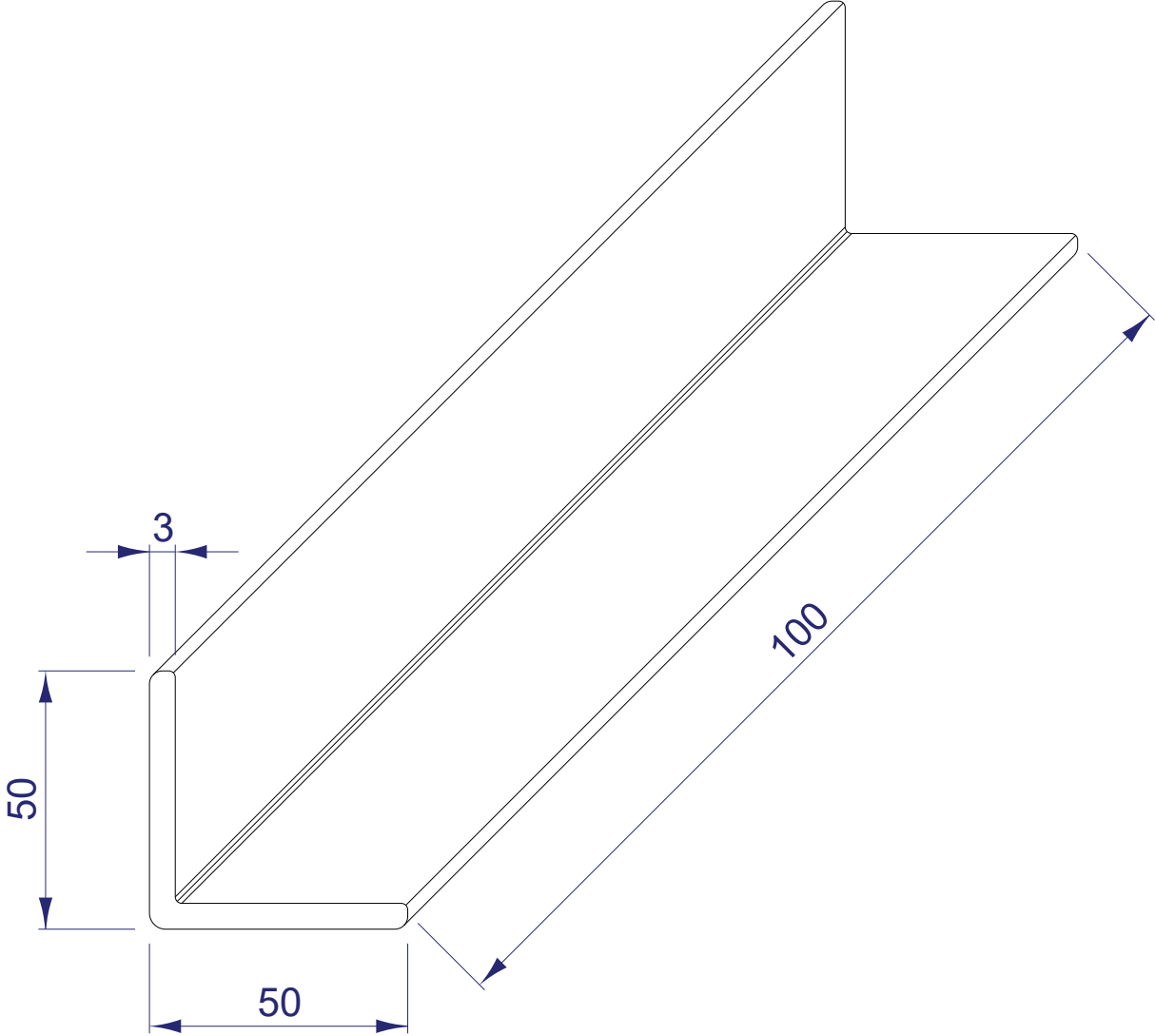

Drawing shows outside view



material: Vollpappe /	
dimension (mm): 50 x 50 x 100	
ascertained weight ca. (kg):	print:
calculated weight ca. (kg): 0.000	fastener:

Flute-/ Grain direction:	
add. information: strap protection	

Project description: H-pallet 3Wall 400mm	
Project-n°: X000055494_A	
CAD-n°: D048905608	Rev. 0
printing date: 07.02.2024	