

# Bill of material

1600x800x542 mm

POS.	CAD-number	amount	article description	inside Dimension (mm)	material
1	D4899450153 <small>Rev.: A</small>	1	pallet / special /	1600 x 800 x 144	Nadelholz IPPC /
2	D4899448529 <small>Rev.: A</small>	2	04 - Folder-type boxes and trays / 0452 /	994 x 1793 x 5	DIN 2.30 EB /
3	D4899448530 <small>Rev.: A</small>	1	05 - Slide-type boxes / 0501 /	1560 x 760 x 400	DIN 2.96/3 CAA /
4	TRICOR Corner <small>Rev.: 0</small>	8	plastic element / /	64.5 x 0 x 32	Other /
5	D4899449986 <small>Rev.: 0</small>	4	wood element / /	410 x 38 x 38	Nadelholz IPPC /
6	D048905608 <small>Rev.: 0</small>	4	corner protector / /	50 x 50 x 100	Vollpappe /



project description

**T-pallet 3Wall 400mm**

printing date

07.02.2024

Project weight (kg)

28.5

**X000055510\_A**

# Specification

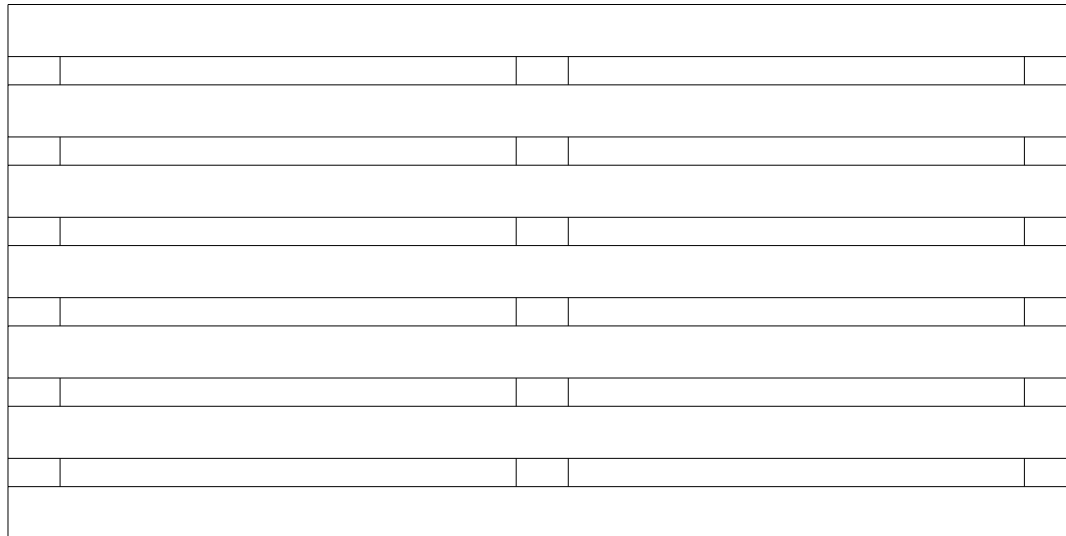
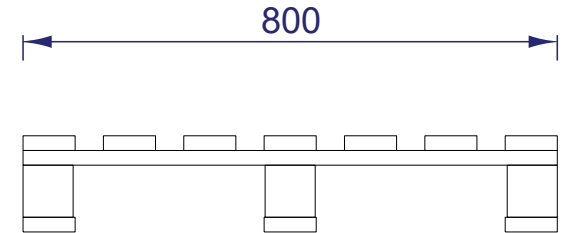
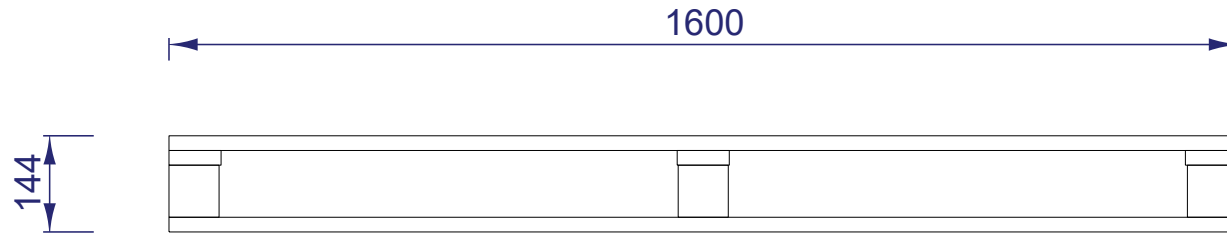

7 Top Board 1600 x 78 x 22mm
3 Middle Board 800 x 78 x 22mm
9 Wooden Block 75 x 75 x 78mm
3 Bottom Board 1600 x 78 x 22mm
Nailing: Min. 2 Grooved / screw nails per joint
Tolerance (+/-): 2mm
IPPC standard (yes/no): Yes, stamped
Residual moisture: Max. 20%

Drawing shows outside view



material: Nadelholz IPPC /	
dimension (mm): 1600 x 800 x 144	
ascertained weight ca. (kg): 23	print:
calculated weight ca. (kg): 0.000	fastener:

Flute-/  
Grain direction:



add. information:  
Coniferous wood IPPC

Project description: T-pallet 3Wall 400mm	
Project-n°: X000055510 A	
CAD-n°: D4899450153	Rev. A
printing date: 07.02.2024	

# Specification

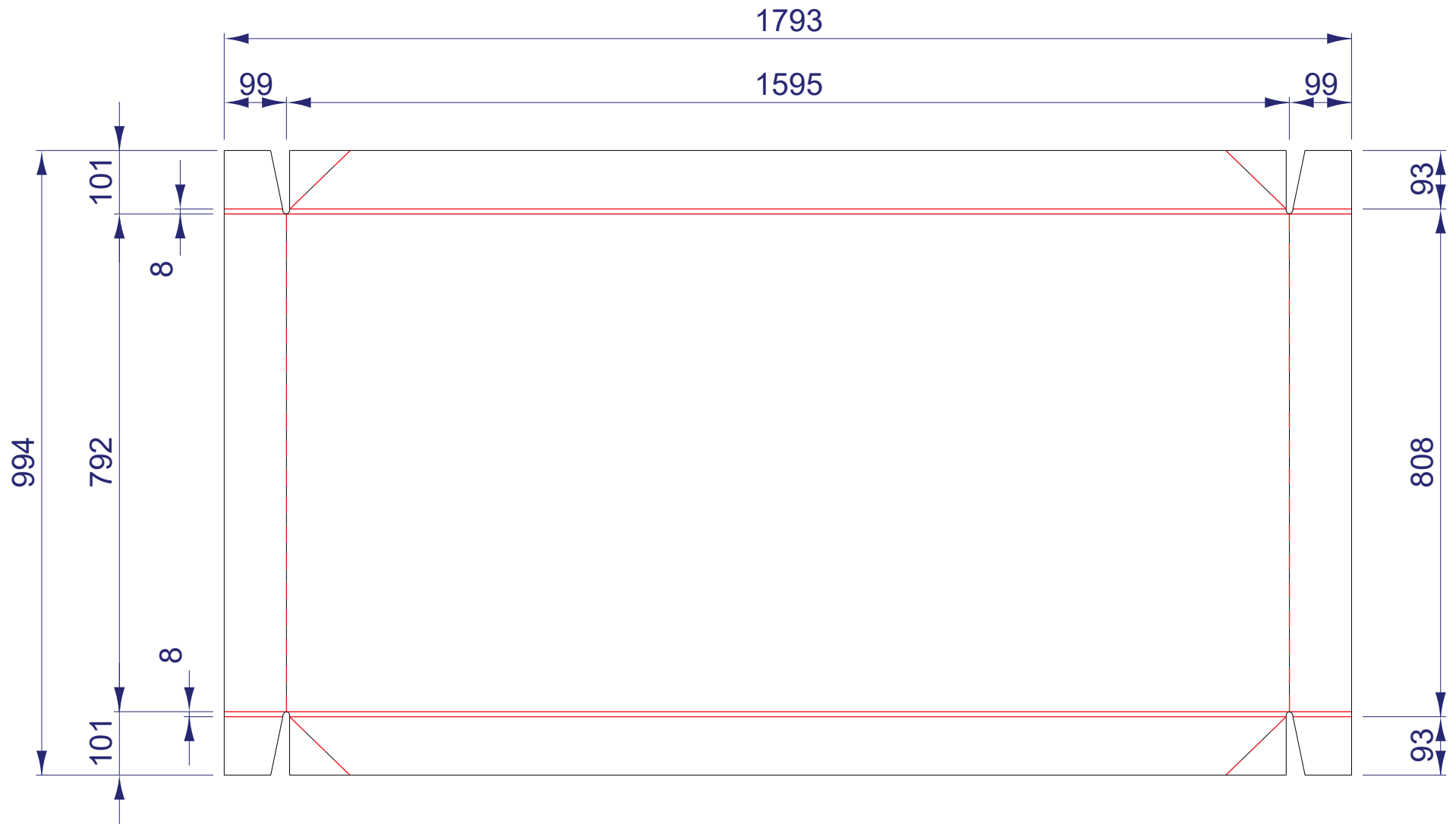

Drawing shows outside view



material: DIN 2.30 EB /	
dimension (mm): 994 x 1793 x 5	
ascertained weight ca. (kg):	print:
calculated weight ca. (kg): 1.136	fastener: 4-corner stitched

Flute-/  
Grain direction:



add. information:  
T-pallet bottom and lid

Project description: T-pallet 3Wall 400mm	
Project-n°: X000055510 A	
CAD-n°: D4899448529	Rev. A
printing date: 07.02.2024	

# Specification

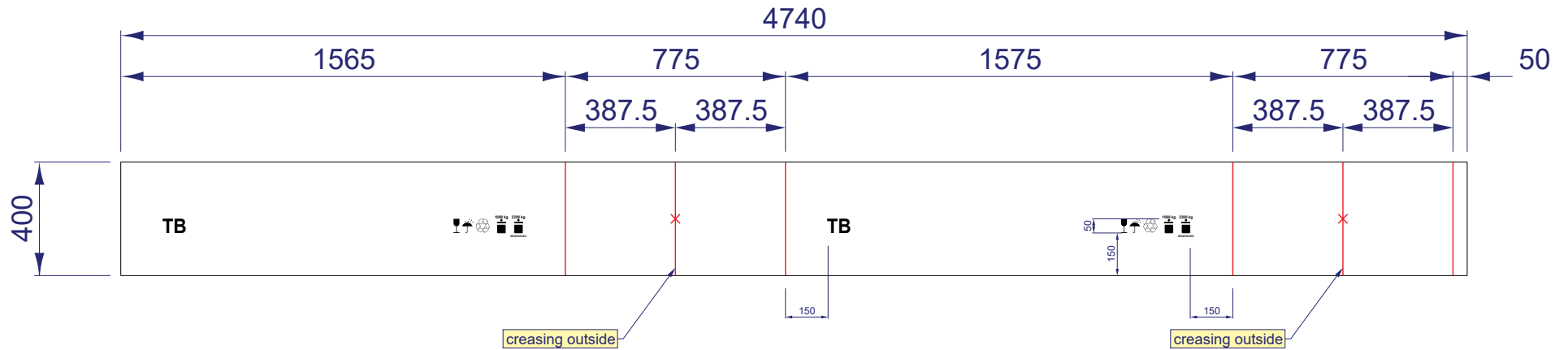

Drawing shows outside view



material: DIN 2.96/3 CAA /	
dimension (mm): 1560 x 760 x 400	
ascertained weight ca. (kg):	print: 1-colored
calculated weight ca. (kg): 3.170	fastener: Inner flap glued and stitched

Flute-/  
Grain direction:



add. information:  
T-Ring CAA 400mm

Project description: T-pallet 3Wall 400mm	
Project-n°: X000055510_A	
CAD-n°: D4899448530	Rev. A
printing date: 07.02.2024	

# Specification

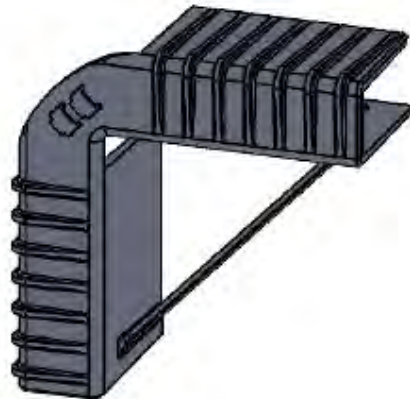
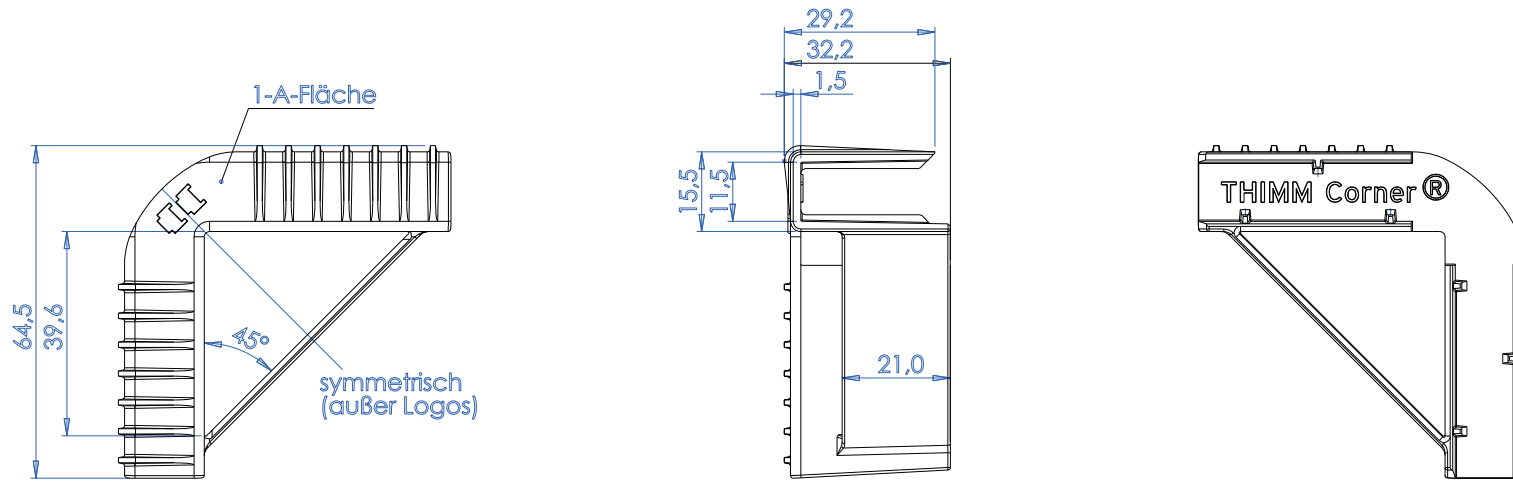

Toleranzen nach: DIN 16742 - TG3  
 Material: Papercompound  
 Gewicht: 13,35 g

Drawing shows outside view



material: Other /	
dimension (mm): 64.5 x 0 x 32	
ascertained weight ca. (kg):	print:
calculated weight ca. (kg): 0.000	fastener:

Flute-/  
Grain direction:



add. information:

Project description: T-pallet 3Wall 400mm	
Project-n°: X000055510_A	
CAD-n°: TRICOR Corner 0	Rev.
printing date: 07.02.2024	

# Specification

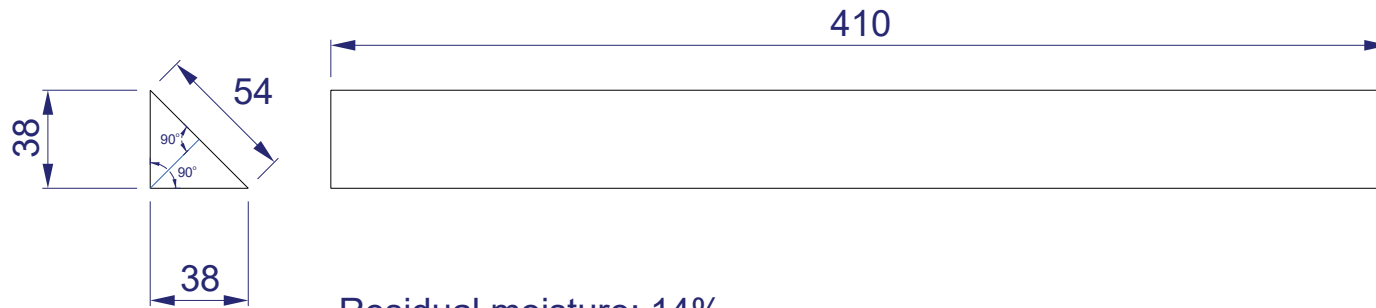

Residual moisture: 14%  
 Tolerance  
 38mm (+0/-1,5)  
 54mm (+0/-2)  
 410mm (+0/-2)

Apply IPPC stamp in the middle of the 54mm wide area

Wooden strips must be free of cracks and knots  
 knotholes and clusters of knotholes.

**not permitted**  
**a ≠ b**

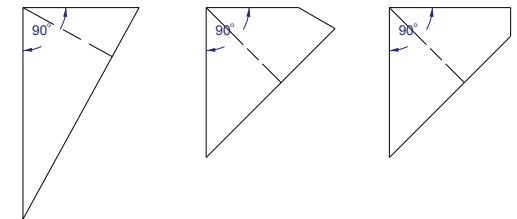

Drawing shows outside view



material: Nadelholz IPPC /	
dimension (mm): 410 x 38 x 38	
ascertained weight ca. (kg): 0.14	print:
calculated weight ca. (kg): 0.000	fastener:

Flute-/  
 Grain direction:



add. information:  
 Coniferous wood IPPC

Project description: T-pallet 3Wall 400mm	
Project-n°: X000055510_A	
CAD-n°: D4899449986	Rev. 0
printing date : 07.02.2024	

# Specification

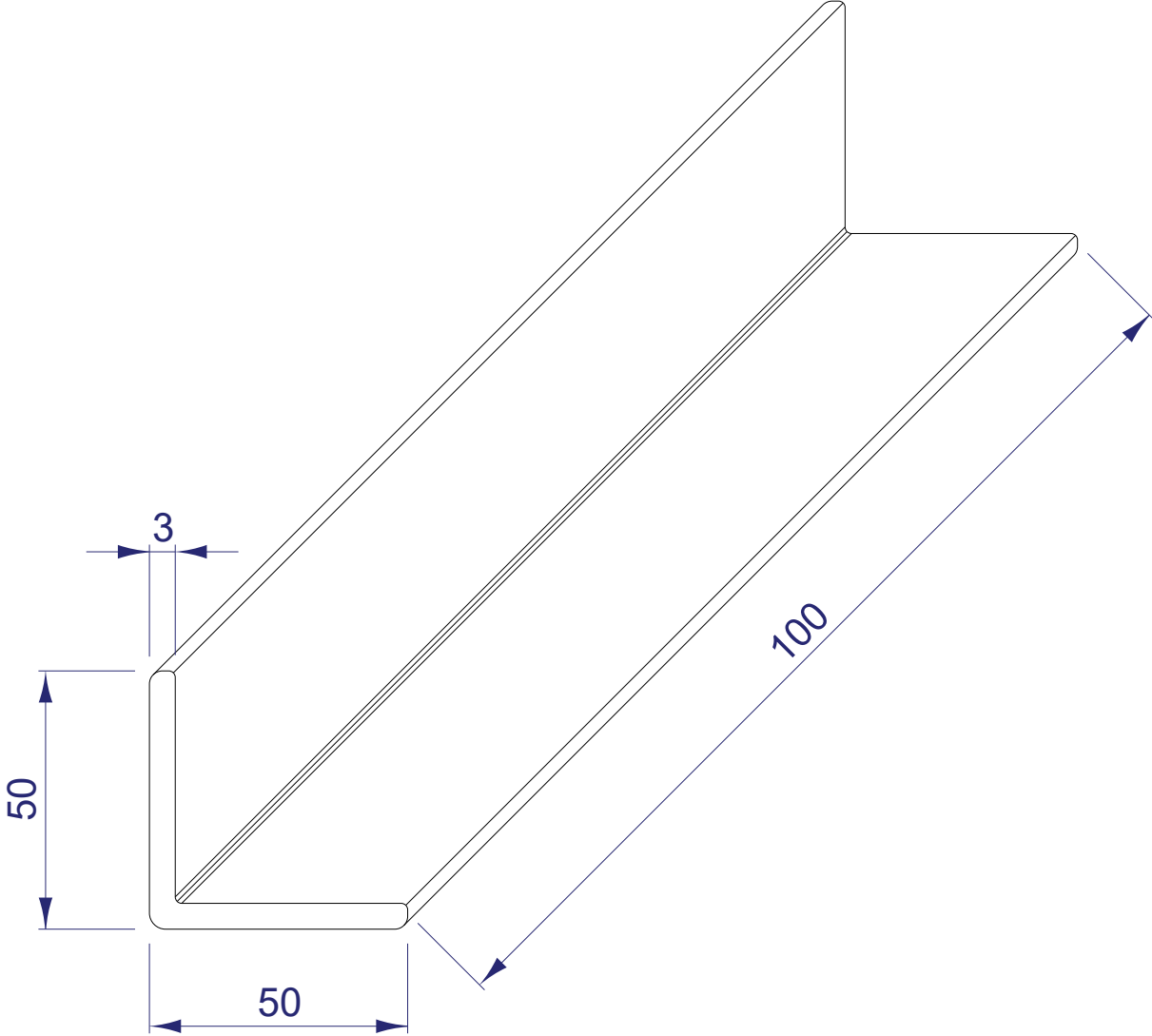

Drawing shows outside view



material: <b>Vollpappe /</b>	
dimension (mm): <b>50 x 50 x 100</b>	
ascertained weight ca. (kg):	print:
calculated weight ca. (kg): <b>0.000</b>	fastener:

Flute-/ Grain direction:	
add. information: <b>strap protection</b>	

Project description: <b>T-pallet 3Wall 400mm</b>	
Project-n°: <b>X000055510 A</b>	
CAD-n°: <b>D048905608</b>	Rev. <b>0</b>
printing date : <b>07.02.2024</b>	