

# Bill of material

2650x1200x742 mm

POS.	CAD-number	amount	article description	inside Dimension (mm)	material
1	D4899450158 <small>Rev.: A</small>	1	pallet / special /	2650 x 1200 x 144	Nadelholz IPPC /
2	D4899448395 <small>Rev.: A</small>	2	04 - Folder-type boxes and trays / 0452 /	1394 x 2843 x 5	DIN 2.30 EB /
3	D4899450107 <small>Rev.: 0</small>	1	05 - Slide-type boxes / 0501 /	2610 x 1160 x 600	DIN 2.96/3 CAA /
4	TRICOR Corner <small>Rev.: 0</small>	8	plastic element / /	64.5 x 0 x 32	Other /
5	D4899449987 <small>Rev.: 0</small>	4	wood element / /	610 x 38 x 38	Nadelholz IPPC /
6	D048905608 <small>Rev.: 0</small>	4	corner protector / /	50 x 50 x 100	Vollpappe /



project description

**X-pallet 3Wall 600mm with 1 Flap**

printing date

07.02.2024

Project weight (kg)

64.1

**X000055616\_A**

# Specification

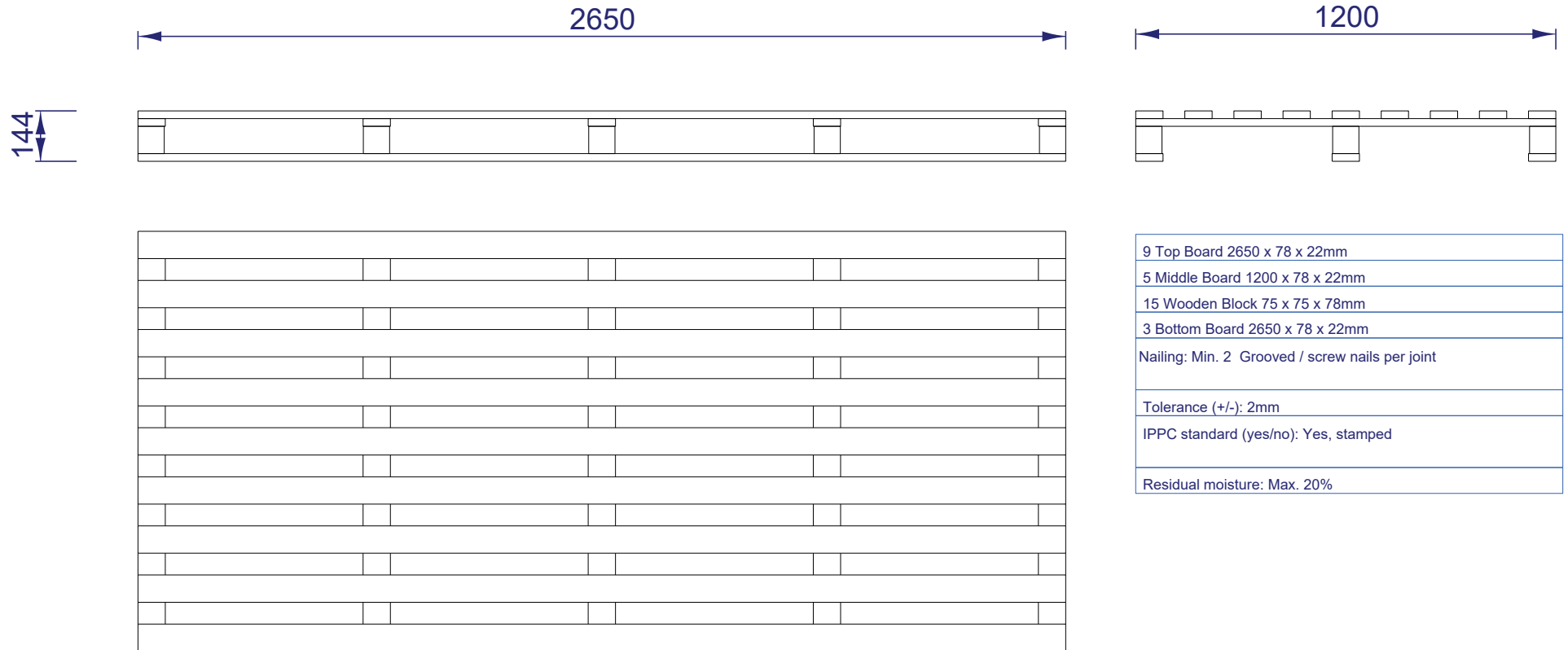

9 Top Board 2650 x 78 x 22mm
5 Middle Board 1200 x 78 x 22mm
15 Wooden Block 75 x 75 x 78mm
3 Bottom Board 2650 x 78 x 22mm
Nailing: Min. 2 Grooved / screw nails per joint
Tolerance (+/-): 2mm
IPPC standard (yes/no): Yes, stamped
Residual moisture: Max. 20%

Drawing shows outside view



material: Nadelholz IPPC /	
dimension (mm): 2650 x 1200 x 144	
ascertained weight ca. (kg): 50.5	print:
calculated weight ca. (kg): 0.000	fastener:

Flute-/  
Grain direction:



add. information:  
Coniferous wood IPPC

Project description:  
X-pallet 3Wall 600mm with 1 Flap

Project-n°:  
X000055616 A

CAD-n°:  
D4899450158 A

printing date:  
07.02.2024

# Specification

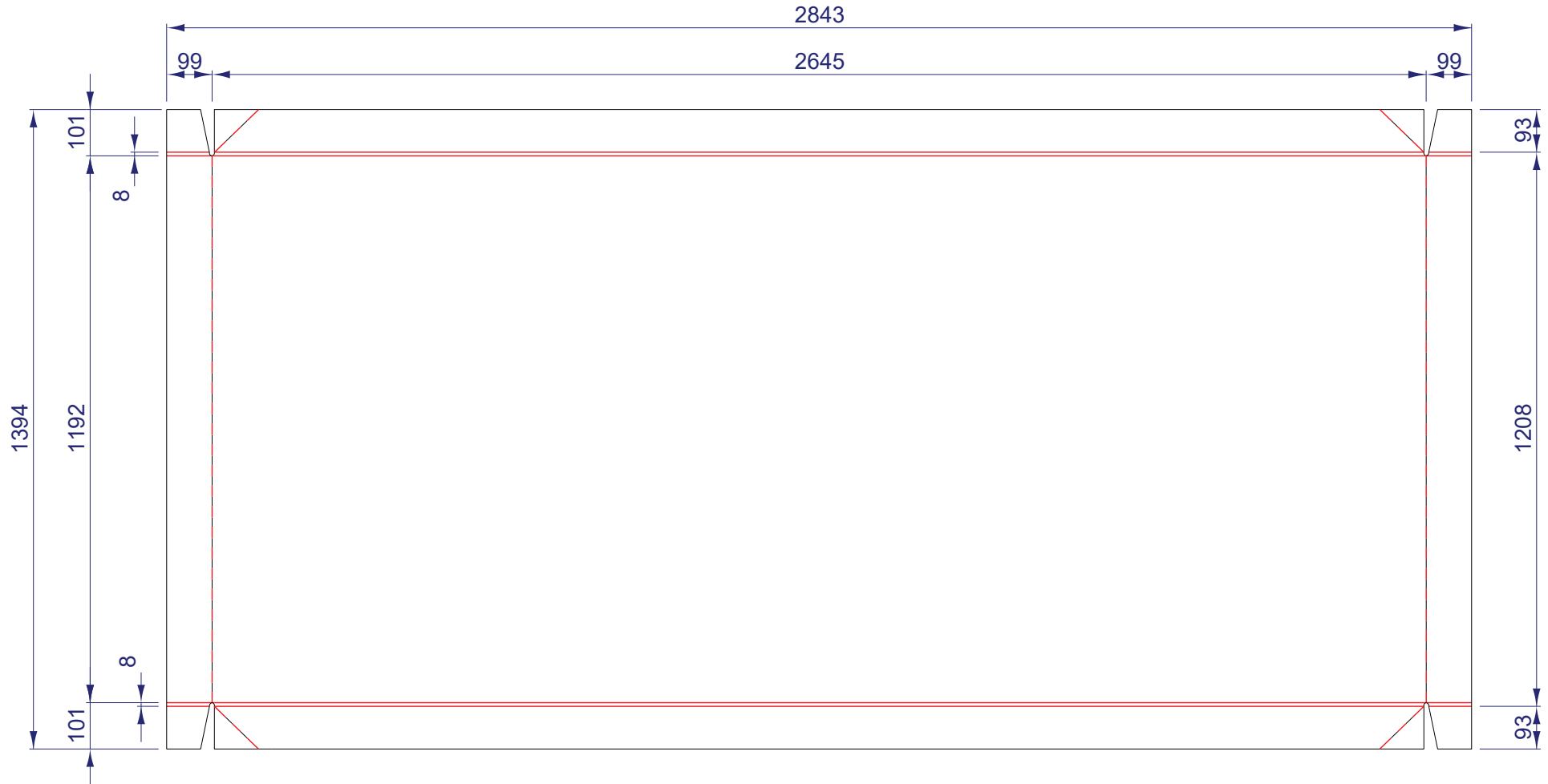

Drawing shows outside view



material: DIN 2.30 EB /	
dimension (mm): 1394 x 2843 x 5	
ascertained weight ca. (kg):	print:
calculated weight ca. (kg): 2.531	fastener: 4-corner stitched

Flute-/  
Grain direction:



add. information:  
X-pallet bottom and lid

Project description: X-pallet 3Wall 600mm with 1 Flap	
Project-n°: X000055616 A	
CAD-n°: D4899448395	Rev. A
printing date: 07.02.2024	

# Specification

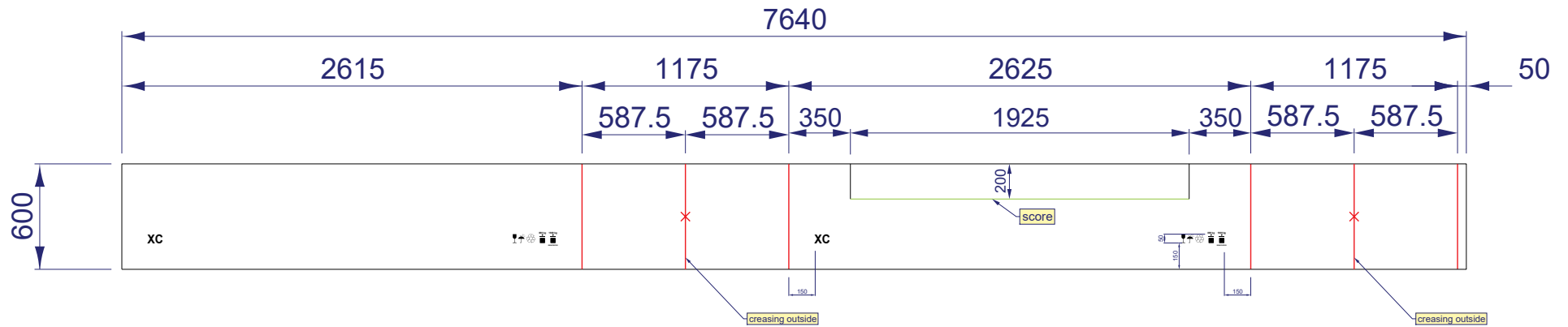

Drawing shows outside view



material: DIN 2.96/3 CAA /	
dimension (mm): 2610 x 1160 x 600	
ascertained weight ca. (kg):	print: 1-colored
calculated weight ca. (kg): 7.664	fastener: Inner flap glued and stitched

Flute-/  
Grain direction:



add. information:  
X-Ring 600mm 1 flap

Project description: X-pallet 3Wall 600mm with 1 Flap	
Project-n°: X000055616_A	
CAD-n°: D4899450107	Rev. 0
printing date: 07.02.2024	

# Specification

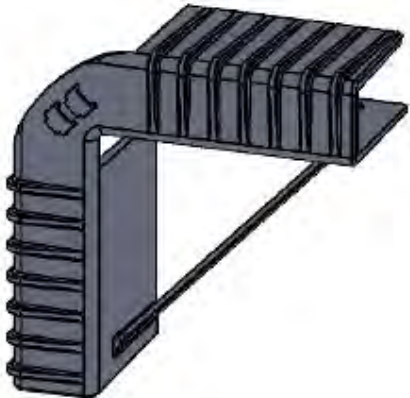
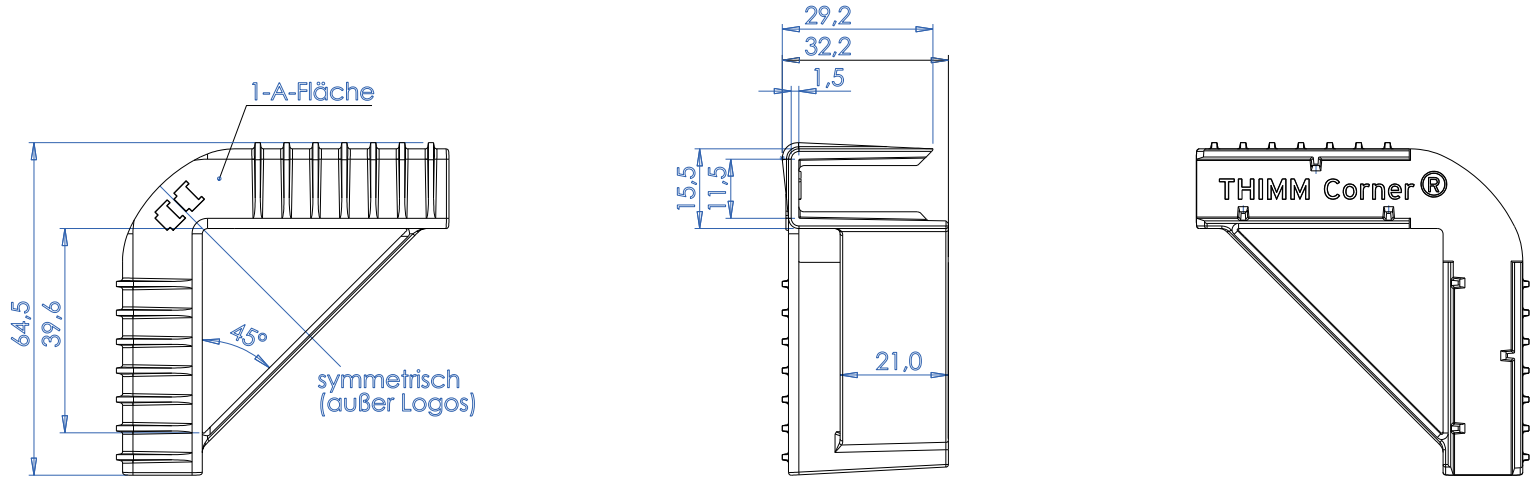

Toleranzen nach: DIN 16742 - TG3  
 Material: Papercompound  
 Gewicht: 13,35 g

Drawing shows outside view



material: Other /	
dimension (mm): 64.5 x 0 x 32	
ascertained weight ca. (kg):	print:
calculated weight ca. (kg): 0.000	fastener:

Flute-/ Grain direction:	
	add. information:

Project description: X-pallet 3Wall 600mm with 1 Flap	
Project-n°: X000055616_A	
CAD-n°:	Rev.
TRICOR Corner 0	
printing date: 07.02.2024	

# Specification

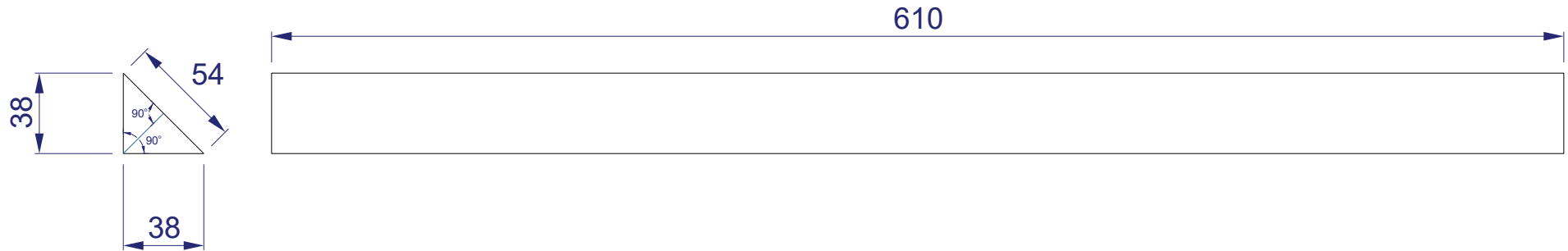

Residual moisture: 14%  
 Tolerance  
 38mm (+0/-1,5)  
 54mm (+0/-2)  
 610mm (+0/-2)

Apply IPPC stamp in the middle of the 54mm wide area

Wooden strips must be free of cracks and knots  
 knotholes and clusters of knotholes.

**not permitted**  
**a ≠ b**

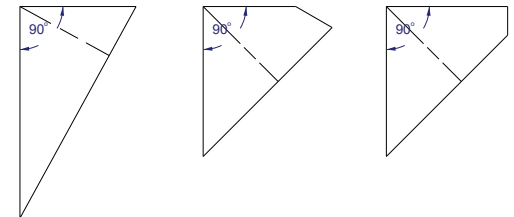

Drawing shows outside view



material: Nadelholz IPPC /	
dimension (mm): 610 x 38 x 38	
ascertained weight ca. (kg): 0.22	print:
calculated weight ca. (kg): 0.000	fastener:

Flute-/  
 Grain direction:



add. information:  
 Coniferous wood IPPC

Project description:  
 X-pallet 3Wall 600mm with 1 Flap

Project-n°:  
 X000055616\_A

CAD-n°:  
 D4899449987\_0

printing date :  
 07.02.2024

# Specification

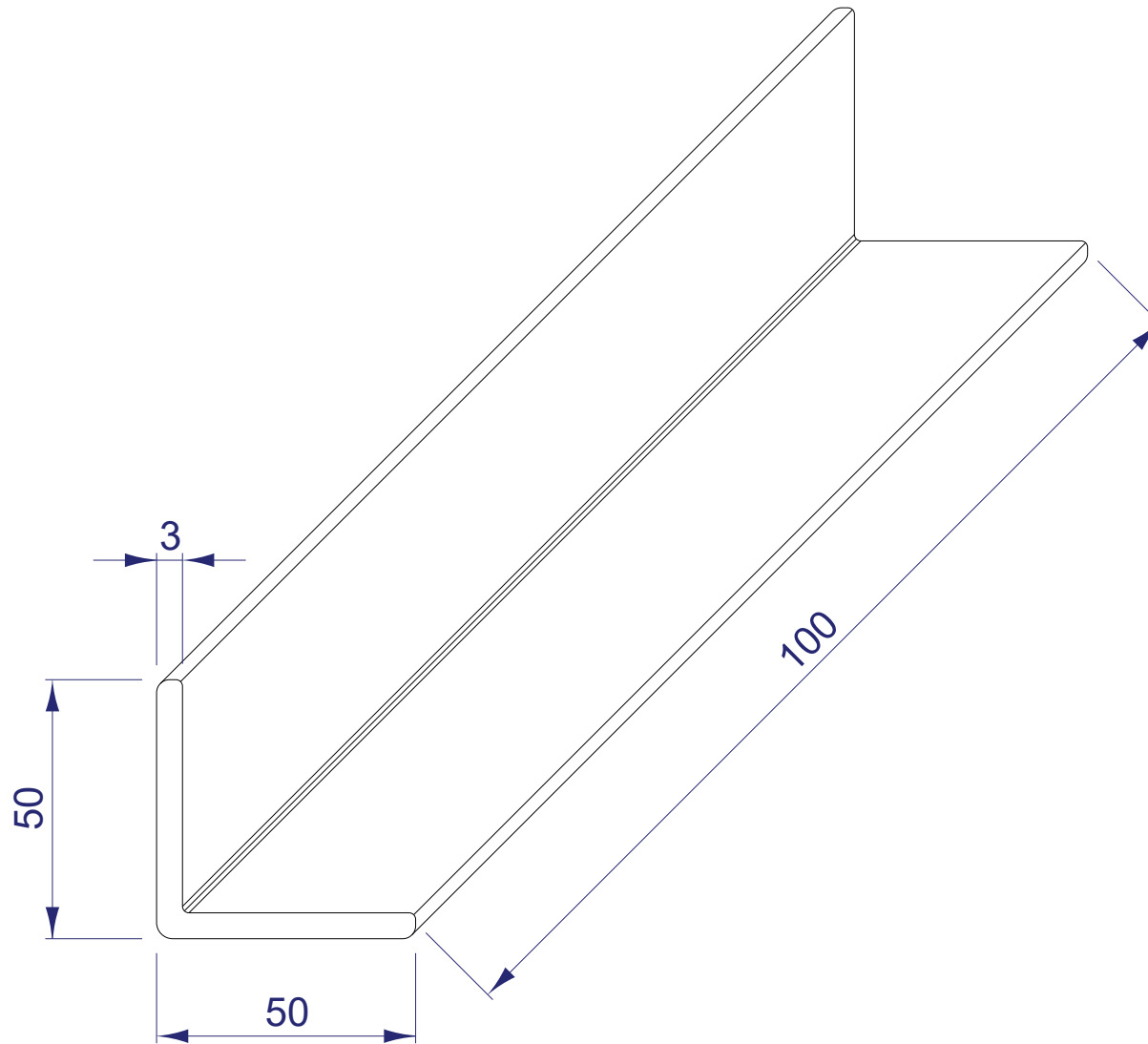

Drawing shows outside view



material: Vollpappe /	
dimension (mm): 50 x 50 x 100	
ascertained weight ca. (kg):	print:
calculated weight ca. (kg): 0.000	fastener:

Flute-/  
Grain direction:



add. information:  
strap protection

Project description:  
X-pallet 3Wall 600mm with 1 Flap

Project-n°:  
X000055616\_A

CAD-n°:  
D048905608

Rev.  
0

printing date:  
07.02.2024