



Document type
REQUIREMENT SPECIFICATION

Title
Requirement specification for Green Long Steel

File name
Requirement specification for Green Long Steel – v 2.0

Validation Date
2024-02-20

Info class
External

Issue
2

Page
1(11)

Approved by (department acronym, name)
SN, Gabrielle Schröder

Issued by (department acronym name phone)
SNRS, Aman Kapoor

REQUIREMENT SPECIFICATION FOR GREEN LONG STEEL

Change History

Issue	Issue date	Change from the previous issue
1	2022-12-20	First issue of Requirement Specification for Green Long Steel
2	2024-02-20	Addition of exception of alloying compounds; $\leq 1\%$ virgin iron to 100% scrap



Document type
REQUIREMENT SPECIFICATIONS

Title
Requirement specification for Green Long Steel

File name
Requirement specification for Green Long Steel – v 2.0

Validation Date
2024-02-20

Info class
External

Issue
2

Page
2(11)

Approved by (department acronym, name)
SN, Gabrielle Schröder

Issued by (department acronym name phone)
SNRS, Aman Kapoor

TABLE OF CONTENTS

1. Introduction.....	3
2. Scope.....	3
3. Background.....	3
3.1 Purpose	3
3.2 Scania’s 2030 supply chain decarbonisation strategy	3
4. Requirements for green long steel.....	3
4.1 Requirement on 100% EAF with 100% steel scrap or H2 DRI	3
4.1.1 Verification of the requirement	5
4.2 Requirement on fossil-free electricity for Tier 1 suppliers, in EAF and in H2 DRI production process	5
4.2.1 How to acquire fossil-free electricity and its verification	5
5. Contact.....	8
6. Confirmation/ Signature.....	9
7. Glossary	9



Document type	REQUIREMENT SPECIFICATIONS	
Title	Requirement specification for Green Long Steel	
File name	Requirement specification for Green Long Steel – v 2.0	
Validation Date	2024-02-20	Info class
Issue	2	External
		Page
		3(11)

Approved by (department acronym, name)
SN, Gabrielle Schröder
Issued by (department acronym name phone)
SNRS, Aman Kapoor

1. INTRODUCTION

This specification document describes Scania's requirements for purchasing of parts/components manufactured from long steel.

2. SCOPE

This specification applies to all sourcings of parts and components containing long steel.

3. BACKGROUND

3.1 Purpose

Scania aims to position itself as a leader in supply chain decarbonisation, i.e. driving the shift towards a sustainable transport system. To take responsibility for our emissions and to contribute to the joint global goal of the Paris Agreement, we need to reduce our emissions over the entire life cycle of our products. In the supply chain, the emissions are going to be ever so important as the shift towards electrification increases the emissions coming from the supply chain.

3.2 Scania's 2030 supply chain decarbonisation strategy

In order to reach our ambition, a 2030 Supply Chain Decarbonisation Strategy has been developed aiming to give us the tools to minimize our supply chain emissions from emission hotspots (batteries, steel, cast iron, and aluminum) by 2030. Suppliers supplying parts and/or components to Scania that contain one or more of the emission hotspots shall switch to lower emission production processes in line with our requirements to collectively contribute to the decarbonisation of these hotspots.

4. REQUIREMENTS FOR GREEN LONG STEEL

Scania's definition of Green Long Steel is **steel that has been produced using the Electric Arc Furnace (EAF) production process with 100% steel scrap (exception alloying compounds; ≤1% virgin iron), or direct reduced iron where hydrogen has been used as the reduction agent (H2 DRI); or with the combination of both of the sources. Only fossil-free electricity has been used in EAF, hydrogen production, direct reduction of iron, and in our direct (tier 1) supplier's production processes.**

4.1 Requirement on 100% EAF with steel scrap or H2 DRI

By 2030, Scania **requires** all parts/components containing long steel to **only** include green long steel that has been produced with **100% EAF** (Electric Arc Furnace). As a feed to the EAF, Scania has the **requirement** of choosing between the following two options or a combination of these options:

Approved by (department acronym, name)
SN, Gabrielle Schröder

Issued by (department acronym name phone)
SNRS, Aman Kapoor

Option 1 (preferred): 100% scrap in EAF (except alloying compounds; ≤1% virgin iron)

In this production technique, the first step is to acquire 100% steel scrap which is fed into the Electric Arc Furnace (EAF). The exception is alloying additions and a maximum allowance of 1% virgin iron if needed for process requirements. From the EAF, electrodes generate a current to melt the steel scrap to produce raw/crude steel. Some carbon is needed so that steel can be produced. This carbon can come from pulverized coal, biomethane, or other biogenic carbon sources. Following this, raw/crude steel then goes through the traditional route of casting, rolling, and finishing steps to ultimately produce green long steel.

Option 2 (if steel scrap is not available): H2 DRI + EAF.

If steel scrap is not available, H2 DRI + EAF is also acceptable. Also a combination of option 1 and 2 can be used by supplier to adjust the production process according to scrap availability.

In this production technique, green hydrogen is to be acquired that is produced through the electrolysis of water, which shall be supplied with fossil-free electricity only (refer to paragraph 4.2 for definition). This hydrogen is then used as a reduction agent to reduce the iron ore pellets to “Hot Briquetted Iron (HBI)” in a Direct Reduction Plant (moving bed shaft furnace). The Hot Briquetted Iron either in the hot form (HDRI) or cold form (CDRI) is then fed to an Electric Arc Furnace. From the EAF, electrodes generate a current to melt the DRI to produce raw/crude steel. Some carbon is needed so that steel can be produced. This carbon can come from pulverized coal, biomethane, or other biogenic carbon sources. Following this, raw/crude steel then goes through the traditional route of casting, rolling, and finishing steps to ultimately produce green long steel.

Below is a schematic flow chart of the process.

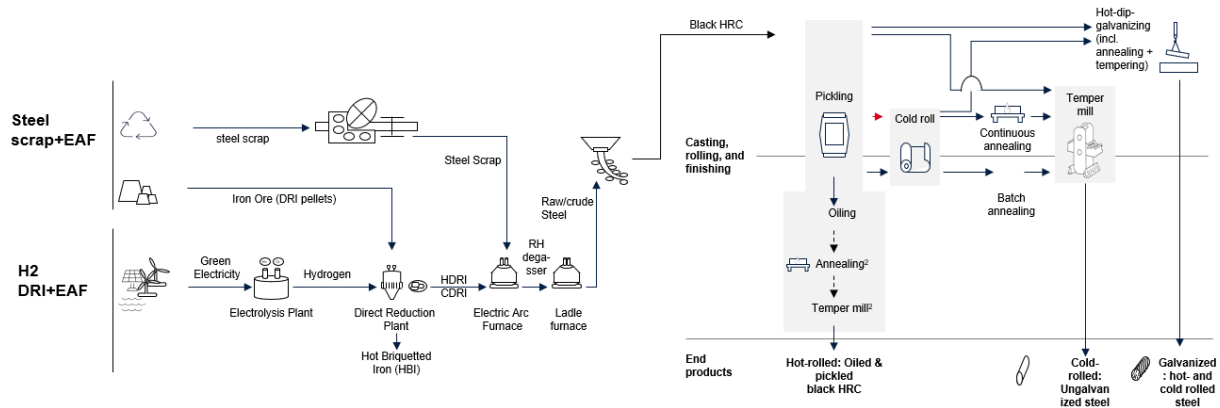

Figure 1: Steel scrap (H2 DRI alternate) + EAF Green Long Steel Production technique



Document type	REQUIREMENT SPECIFICATIONS	
Title	Requirement specification for Green Long Steel	
File name	Requirement specification for Green Long Steel – v 2.0	
Validation Date	2024-02-20	Info class
Issue	2	External
		Page
		5(11)

Approved by (department acronym, name)
SN, Gabrielle Schröder
Issued by (department acronym name phone)
SNRS, Aman Kapoor

Scania’s suppliers are to **ensure compliance** with the requirement by cascading the requirement to sub-suppliers (Tier 2 and beyond) who are manufacturing long steel.

4.1.1 Verification of the requirement

Suppliers are to verify the above process requirement by signing this requirement specifications document along with filling an online decarbonisation questionnaire where they confirm their compliance with above process requirement. In this questionnaire, the supplier shall declare the **description of the process** for H2 DRI + EAF (if used), and the share of steel scrap used in the process.

4.2 Requirement on fossil-free electricity for Tier 1 suppliers, in EAF and in H2 DRI production process

Scania requires the **electricity used in the production** processes of Tier 1 suppliers supplying parts/components containing long steel to be **fossil-free**. The share of fossil-free electricity required is **50% by 2025** and **100% by 2030**.

Further, Scania requires the use of **fossil-free electricity in the EAF process, and if applied, in all production steps of the H2 DRI process** to produce green long steel that is supplied to Scania. This shall be ensured in the EAF step also including the casting, rolling, and the finishing step. For H2 + DRI, the requirement applies from the beginning, which includes the hydrogen production, direct reduction of iron, and electric arc furnace.

Scania’s suppliers are to **ensure compliance** with the requirement by cascading the requirement to sub-suppliers (Tier 2 and beyond) who are manufacturing long steel.

Fossil-free electricity should be interpreted as renewable energy sources or nuclear energy. Renewable energy sources include wind, solar, hydropower, geothermal, tidal, and biofuels (we strongly recommend waste-based biofuels compared to crop-based biofuels).

4.2.1 How to acquire fossil-free electricity and its verification

Supplier shall provide **evidence of using fossil-free electricity, its consumption figures, and certificates** to Scania applying both for Tier 1, and for sub-suppliers using the EAF production process. If H2 DRI is used, evidence of use of fossil-free electricity in both hydrogen production and in direct reduction of iron shall be provided.

Fossil-free electricity shall be obtained and verified in either of the following ways:

- i. **Purchase of fossil-free electricity from a fossil-free power supply contract**
The Supplier signs a power supply contract for fossil-free electricity with an energy supplier (energy supply company, utility). This supplies the customer (here supplier) with the required electrical energy. In partially or fully liberalized markets, energy suppliers often use a special fossil-free/green power product for which they purchase Green Energy Certificates (EAC) and cancel them in favor of the product. This ensures that the fossil-free energy

Approved by (department acronym, name)

SN, Gabrielle Schröder

Issued by (department acronym name phone)

SNRS, Aman Kapoor

that is supplied to the customer is correctly taken from the country's energy mix. In liberalized markets, the energy supplier also identifies the product in its own electricity labeling (fuel mix disclosure). As a rule, the energy suppliers have their fossil-free products certified by independent third parties or government agencies and have the appropriate product certificates. The fossil-free electricity production shall be sourced in the same electricity area with good transmission possibilities and connections as the consumption facilities are placed as a first priority. If this is not possible, then the electricity can be sourced from a different electricity area as long as it is from the same geographical region.

Verification: The supplier shall provide proof of its and sub-suppliers' (when applicable) fossil-free electricity supply by specifying the fossil-free supply contract and a corresponding certificate of attestation from its energy supplier. In some markets, it is possible for the customer (here supplier) to maintain their own registered accounts via GoO (Guarantees of Origin) and to validate GoO for themselves. In these cases, proof of fossil-free power supply is also possible via the cancellation reports.

In addition, the documents also need to specify the consumption figures of the electricity usage and the type of electricity source used. Consumption is expressed in kWh or MWh in series production. If necessary, consumption in series production can be calculated on the based on pre-series production.

Summary of all documents to be submitted to Scania:

- **Prior to the nomination:** description of energy concept in the decarbonisation questionnaire (what energy sources will be used, which of the acquirement options will be applied). In addition, this requirement specifications sheet must be signed by the supplier.
 - **Prior to start of the production:** the information on the energy supplier and the procured quantities. Any concept changes before and after the start of production shall be communicated by the supplier in advance to Scania.
 - **Subsequently every year (in February):** certificates, evidence of fossil free electricity contracts along with its consumption figures, declaration of self-consumption and proof of generation, if applicable.
- ii. **Contractual solutions as Power Purchase Agreements (PPA), Renewable Energy Certificates (REC) or similar renewable contractual solutions.**
Fossil-free electricity can be directly purchased from plant parks through long-term commitments. Such purchase contracts, which are usually multi-year contracts, are called Power Purchase Agreements (PPA). In these cases, the customer (here supplier) often receives GoO or corresponding cancellation reports directly from the contractual partner. The fossil-free

Approved by (department acronym, name)

SN, Gabrielle Schröder

Issued by (department acronym name phone)

SNRS, Aman Kapoor

electricity production shall be sourced in the same electricity area with good transmission possibilities and connections as the consumption facilities are placed as a priority. If this is not possible, then the electricity can be sourced from a different electricity area as long as it is from the same geographical region.

Verification: The supplier shall provide its and sub-suppliers' (when applicable) origin of fossil-free electricity through the PPA agreement contract document which is controlled by an officially independent authority or control unit for an actual geographic region. Examples of acceptable contractual standardized solutions are GoOs, RECs, I-RECs, etc. In addition, the documents also need to specify the consumption figures of the electricity usage and the type of electricity source used. Consumption is expressed in kWh or MWh in series production. If necessary, consumption in series production can be calculated on the basis of pre-series production.

Summary of all documents to be submitted to Scania:

- **Prior to the nomination:** description of energy concept in the decarbonisation questionnaire (what energy sources will be used, which of the acquirement options will be applied). In addition, this requirement specifications sheet must be signed by the supplier.
- **Prior to start of the production:** the information on the energy supplier and the procured quantities. Any concept changes before and after the start of production shall be communicated by the supplier in advance to Scania.
- **Subsequently every year (in February):** certificates, evidence of fossil free electricity contracts along with its consumption figures, declaration of self-consumption and proof of generation, if applicable.

iii. **On-site generation and own consumption from renewable energy sources**

Suppliers are permitted to generate and use their own renewable energy from sources such as photovoltaic panels, wind power, CHP assets, or similar renewable assets at the site.

However, it must be ensured from the energy produced through these sources that:

- it receives no subsidies
- is not fed into the upstream power grid
- it does not receive feed-in tariffs.

Conversely, this means that it is only valid if the electricity generated is completely consumed by the supplier itself (own consumption).

Approved by (department acronym, name)

SN, Gabrielle Schröder

Issued by (department acronym name phone)

SNRS, Aman Kapoor

Verification: The supplier shall declare its and sub-suppliers' (when applicable) self-consumption and show proof of generation. In addition, the documents also need to specify the consumption figures of the electricity usage and the type of electricity source used. Consumption is expressed in kWh or MWh in series production. If necessary, consumption in series production can be calculated on the basis of pre-series production.

Summary of all documents to be submitted to Scania:

- **Prior to nomination:** description of energy concept in the decarbonisation questionnaire (what energy sources will be used, which of the acquirement options will be applied). In addition, this requirement specifications sheet must be signed by the supplier.
- **Prior to start of the production:** the information on the energy supplier and the procured quantities. Any concept changes before and after the start of production shall be communicated by the supplier in advance to Scania.
- **Subsequently every year (in February):** certificates, evidence of fossil free electricity contracts along with its consumption figures, declaration of self-consumption and proof of generation, if applicable.

iv. **Special note for non-liberalized markets/ energy markets in transition**

Some countries do not yet have deregulated markets or are in the middle of the process of restructuring the energy market (e.g. China). None or not all of the above-mentioned instruments for accounting and marketing of renewable energy are available or fully implemented in these countries. Here, individual case assessments will be carried out between Scania and the supplier.

The following information shall be present in the verification documentation for all the above options to acquire fossil-free electricity:

1. Electricity production source (e.g wind, water, solar etc.)
2. Volume in kWh or MWh
3. Specific electricity production device/unit
4. Relevant production and consumption period
5. Supplier and counterparties
6. Verified by a third party
7. Documentation from EECS, RECS, IRECs or similar official standard system if applicable
8. Unique certificate number

5. CONTACT

Suppliers are to get in touch with their regular contact point at Scania for any queries on these requirement specifications.



Document type	REQUIREMENT SPECIFICATIONS	
Title	Requirement specification for Green Long Steel	
File name	Requirement specification for Green Long Steel – v 2.0	
Validation Date	2024-02-20	Info class
Issue	2	External
		Page
		9(11)

Approved by (department acronym, name)
SN, Gabrielle Schröder
Issued by (department acronym name phone)
SNRS, Aman Kapoor

6. CONFIRMATION/ SIGNATURE

E-Signatures are valid through online platform called “Scrive”. These shall be requested by the purchaser to the supplier to confirm the requirements stated in this document (Once the online signature goes through via “Scrive”, it appears at the end of the document).

By e-signing this document, the supplier confirms that they accept the requirements described in this document “Requirement specification for Green Long Steel” and commit to fully complying with the requirements as they are stated in this specification.

7. GLOSSARY

Long Steel

Long steel is to be defined as steel that is in the form of wire, billets, pipes, rod, rail or bars.

Green Long Steel

Steel that has been produced using the Electric Arc Furnace (EAF) production process with either atleast 90% steel scrap, or direct reduced iron where hydrogen has been used as the reduction agent (H₂ DRI); or with the combination of both of the sources. Only fossil-free electricity has been used in EAF, hydrogen production, direct reduction of iron, and in our direct (tier 1) supplier’s production processes.

Steel Scrap

Steel scrap arising from the disposal of products before or after they have been used.

Fossil-Free Electricity

Refers to renewable energy and nuclear power. It includes wind, solar, hydropower, and biofuels (we strongly recommend waste-based biofuels in comparison to crop-based biofuels).

DRI – Direct Reduced Iron

Direct Reduced Iron (DRI) also called sponge Iron is produced from the direct reduction of the iron ore through hydrogen as the fuel source. Direct reduction refers to solid-state processes which reduce iron oxides to metallic iron below the boiling temperature of iron.

EAF – Electric Arc Furnace

A furnace that heats the material through an electric arc. The temperatures of heat in industrial furnaces are higher than 1,800°C. Inside the furnace, the charged material is exposed directly to the electric arc and the current from the furnace terminals passes through the charged material.



Document type	REQUIREMENT SPECIFICATIONS	
Title	Requirement specification for Green Long Steel	
File name	Requirement specification for Green Long Steel – v 2.0	
Validation Date	2024-02-20	Info class
Issue	2	External
		Page
		10(11)

Approved by (department acronym, name)

SN, Gabrielle Schröder

Issued by (department acronym name phone)

SNRS, Aman Kapoor

SAF – Submerged Arc Furnace

This furnace is similar to EAF, if the arc is buried by the slag and charge and the arc is hidden, then this technique is the submerged Arc Furnace.

EAC – Energy Attribute Certificate

An Energy Attribute Certificate (EAC) is the official documentation to prove renewable energy generation. Each EAC represents proof that 1 MWh of renewable energy has been produced and added to the grid. Global EAC standards for renewable claims are primarily Guarantees of Origin in Europe, RECs in North America, and International RECs (I-RECs) in a growing number of countries in Asia, Africa, the Middle East, and Latin America. EAC is compliant with the Greenhouse Gas Protocol and is a recognised tool for companies to report reduced greenhouse gas emissions and improve sustainability rating.

EECS – European Energy Certificate System

The EECS (European Energy Certificate System) is a standardization system for the European Guarantees of Origin (GO, GoO). Nations that are members of the AIB and adhere to the EECS system are easily able to trade GOs cross-border with no risk of double counting, claiming or attributing.

Electrical Grid, Power Grid

An electrical grid or power grid, is an interconnected network for delivering electricity from producers to consumers. In the electrical power business, a TSO (Transmission Grid Operator) is an operator that transmits electrical power from generation plants over the electrical grid to regional or local electricity distribution operators. Transmission grids usually are at high voltage levels of 110-330 kV.

GoO – Guarantee of Origin

A Guarantee of Origin (GO or GoO) is a tracking instrument defined in article 15 of the European Directive 2009/28/EC. A GO labels electricity from renewable sources to provide information to electricity customers on the source of their energy. Guarantees of origin are the only precisely defined instruments evidencing the origin of electricity generated from renewable energy sources.

PPA – Power Purchase Agreement

A Power Purchase Agreement (PPA) is a long-term contract under which a business agrees to purchase electricity directly from a renewable energy generator. A corporate PPA is where the electricity buyer is a business or company, rather than a utility or the public sector.

In a direct PPA, a contract is established between a company and a power-producing facility to purchase the electricity generated by that facility. Companies with a large energy footprint in a single state or narrow geographic region are typically the best candidates for this type of PPA because the clean power is directly delivered to the account of the facility purchasing that energy. Direct PPAs can be structured in a



Document type	REQUIREMENT SPECIFICATIONS	
Title	Requirement specification for Green Long Steel	
File name	Requirement specification for Green Long Steel – v 2.0	
Validation Date	2024-02-20	Info class
Issue	2	External
		Page
		11(11)

Approved by (department acronym, name)
SN, Gabrielle Schröder
Issued by (department acronym name phone)
SNRS, Aman Kapoor

variety of ways and may require additional parties, such as retail providers or local utilities.

REC – Renewable Energy Certificate

An instrument for documenting and proving the generation of renewable energy similar to the European GoO. Commonly used in the United States of America, Japan, and Canada.

CHP – Combined Heat and Power

Combined Heat and Power, also known as Cogeneration is the concurrent production of electricity or mechanical power and useful thermal energy (Heating and/or cooling) from a single source of energy.